

AMIS-42700 Multiple CAN Bus Network

Prepared by: Tom De Ryck
ON Semiconductor



ON Semiconductor®

<http://onsemi.com>

APPLICATION NOTE

Introduction

This application note describes how a multiple CAN bus network can be made by using AMIS-42700. A customer application is taken as an example.

Application Description

Next gives a simplified representation of the customer's application.

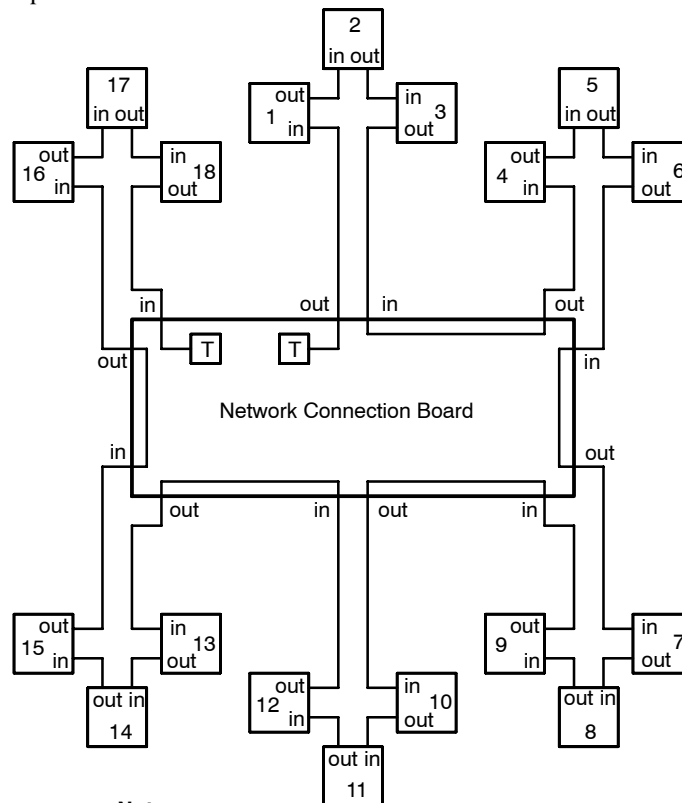

Notes:

- 1 thru 18 are CAN nodes (multimaster network)
- T = termination
- CAN bus drawn as a single line
- Distance between Network Connection Board and CAN node is 2 m

Figure 1. Customer Application

The application consists out of 18 CAN nodes which are grouped in 6 groups. The CAN nodes in one group are located near to each other and at a distance of 2 m to the Network Connection Board. The different CAN node groups are not necessarily close to each other.

Each CAN node consists out of an input and output connection making it easy to connect a CAN node to the CAN bus. Inside the CAN node, the input is connected with the output making one big CAN bus(*).

* Because the input connection of the CAN node is connected with the output connection, input and output can be swapped.

AND8360

Inside the Network Connection Board, termination is foreseen to build the CAN bus in a proper way.

Because the CAN node groups are located at a distance of 2 m from the Network Connection Board, the minimum wire length a signal has to cross between two CAN node groups is 4 m. The maximum wire length is 20 m (for instance when there is communication between node 1 and node 18).

When a fault condition occurs on the bus, no communication is possible anymore between CAN nodes.

6 CAN Bus Network

The problem with the above bus topology is that a total wire length of 24 m is needed. This is too much knowing that only 6 CAN groups are present each at a distance of 2 m from the Network Connection Board. Additionally, if a CAN bus failure occurs, no communication is possible anymore.

Next figure gives a simplified view on how these problems can be solved by using AMIS-42700.

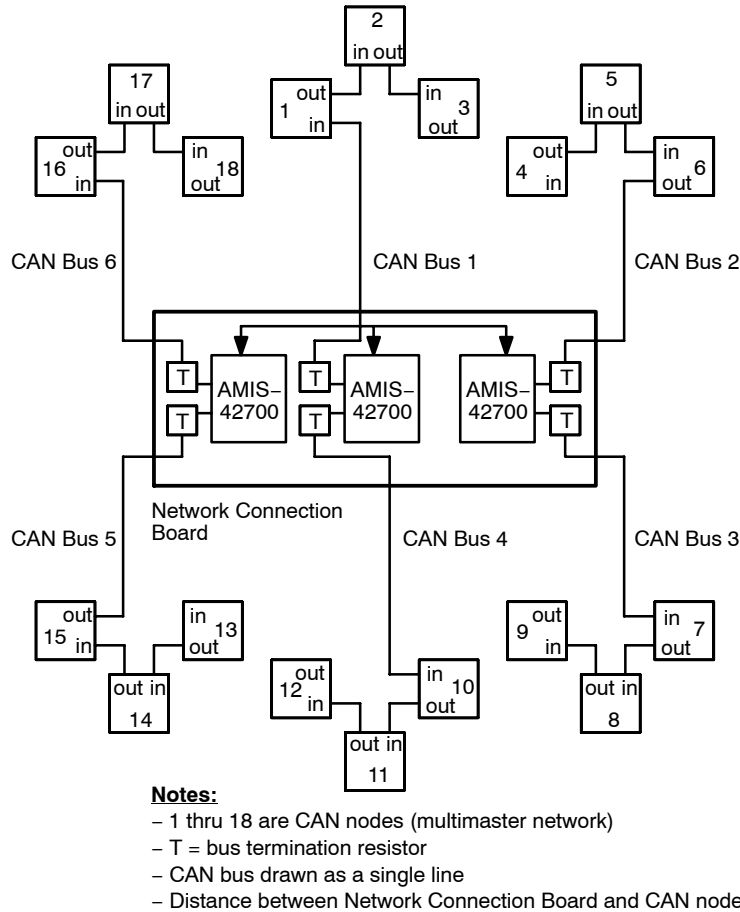

Notes:

- 1 thru 18 are CAN nodes (multimaster network)
- T = bus termination resistor
- CAN bus drawn as a single line
- Distance between Network Connection Board and CAN node is 2 m

Figure 2. 6 CAN Bus Network

To be consequent with the customer application, the same CAN nodes are used in above figure. All CAN nodes are also here located at a distance of 2 m from the Network Connection Board. Notice that now only 12 m of CAN bus cable is needed instead of 24 m.

As can be seen in above figure, all CAN node groups are located on a separate bus. This means that if a CAN bus failure occurs on one CAN bus, communication is still possible on the other busses as also between the other CAN busses.

Notice that there is only one termination foreseen and the end of each CAN bus. In most cases two resistors of 120 Ω are foreseen at each end of the CAN bus. This can also be done here. In our application we only use one resistor (for

each CAN bus) of 60 Ω in the Network Connection Board (see also Figure 3).

Test Set Up

A test set up was built similar to Figure 2. For CAN nodes, the AMIS-3052x Evaluation Kit was used. This kit is the AMIS-3052x stepper motor driver kit which contains a microcontroller with on-chip CAN controller. CAN transceiver used on these CAN nodes is AMIS-30660. A CAN bus cable of 2 m was used to connect the CAN nodes to the Network Connection Board (5,7 ns/m cable propagation delay at 1 MHz).

Next schematic gives a more detailed view on the Network Connection Board.

AND8360

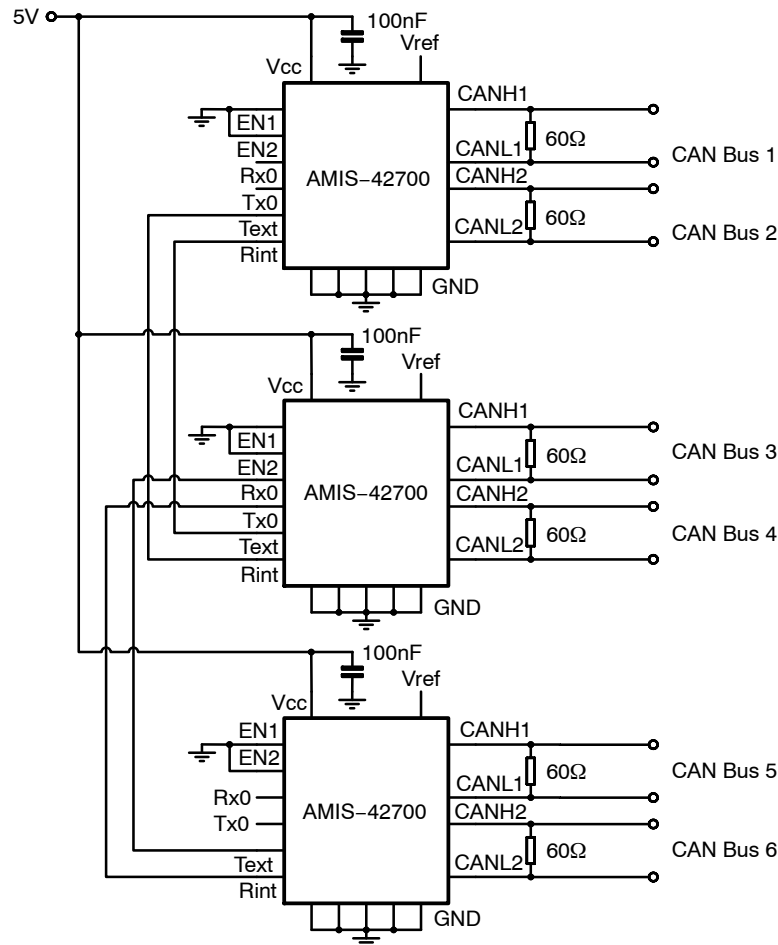

Figure 3. CAN Bus Network Connection Board

As can be seen in above figure, only 3 AMIS-42700 are needed to build a 6 CAN bus network (no additional logic needed).

In the test set up, a 60 Ω termination resistor is foreseen (see Figure 3). This means that at the other end of the CAN bus no termination has to be foreseen anymore.

Knowing that AMIS-42700 introduces bus delay, tests were done to find the upper speed limit.

Limitations

Communication up to 500 kbps is possible^(*). A fault condition on one of the CAN busses will have no effect on the communication on the other busses.

Communication at 1 Mbps was also tried out but is not possible. Why?

AMIS-42700 adds delay to the signal. Taking Figure 3 as a reference, the added signal delay between CAN bus 1 and CAN bus 2 caused by AMIS-42700 will be 245 ns (worst case). Knowing that the used cable in the set up (see Figure 2) has a propagation delay of 5.7 ns, one can say that AMIS-42700 will add delay equal to about 43 m of cable. For the CAN nodes it will look like the CAN cable is 47 m long.

The added delay between CAN bus 1 (or 2) and CAN bus 3 (or 4) will be a few ns more (about 260 ns in total) which is equal to about 45 m of cable. The added signal delay

between CAN bus 1 (or 2) and CAN bus 5 (or 6) will be about 295 ns.

In general, the maximal signal delay added by AMIS-42700 will be 295 ns (in this bus topology). Although the signal only has to propagate over 4m of cable, the added delay by AMIS-42700 will make it look like it's actually about 55 m. Knowing that 1 Mbps CAN communication is limited to 40 m bus length, AMIS-42700 will introduce too much delay to be able to work at a CAN speed of 1 Mbps (in this bus topology).

Multiple CAN Bus Network

The question could arise if it wouldn't be possible to extend this network to 8 CAN busses. The answer is yes.

Figure 4 displays how this can be done.

It is even possible to build a 10 CAN bus network, or a 12 CAN bus network, or a ... by adding additional AMIS-42700. Connect the Tx0 signal with the Rint signal of the next AMIS-42700 as also the Rx0 signal with the Text signal.

If 500 kbps will still be obtainable depends on the network. The more AMIS-42700 are added, the more signal delay will be introduced between a CAN bus of the first AMIS-42700 and a CAN bus of the last AMIS-42700. This has to be kept in mind.

* CAN Bit Length = 8TQ, SJW = 1TQ, TSEG1 = 5TQ, TSEG2 = 2TQ

AND8360

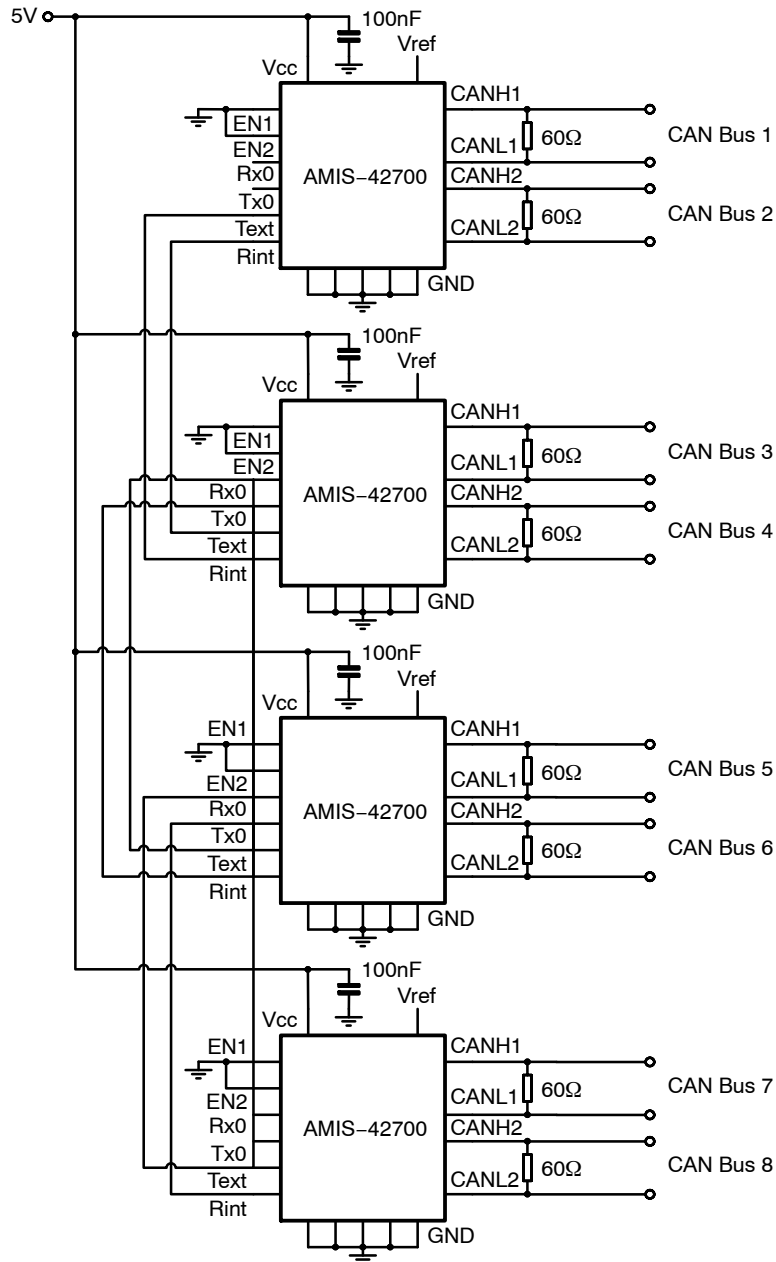

Figure 4. 8 CAN Bus Network

Higher Speed

As mentioned above, 1 Mbps can not be obtained (in this bus topology). Taking the original application (Figure 1), the maximum bus length is 20 m. Although never tested, 1Mbps should be possible in this application.

Does this mean that by using the multiple CAN bus system (e.g. Figure 2) the CAN baudrate always has to be lower than in the original application?

No. Assume that in the original application the CAN node groups are located at a distance of 20 m (instead of 2 m). The worst case bus length will be 200 m. Although never tried, the assumed maximum CAN baudrate will be 250 kbps.

Taking the 6 CAN bus network (Figure 2), the maximum bus length will be 40 m. Knowing that the Network

Connection Board will add signal delay similar to about 50 m of cable (worst case), the total signal delay (in one direction) will be equal to less than 100 m of cable. At this cable length 500 kbps CAN baudrate should be possible.

In the application described in this application note, the maximum CAN baudrate that can be obtained in original application (Figure 1) will be higher than the CAN baudrate that can be obtained when using the 6 CAN bus network (Figure 2). If however the CAN node groups are located at a longer distance from the Network Connection Board, higher CAN baudrate can be achieved by using AMIS-42700.

Central CAN Nodes

In above example, no CAN node is included in the Network Connection Board. Adding a CAN node can be done by connecting it to one of the CAN busses. An easier and cheaper way is displayed in next figure.

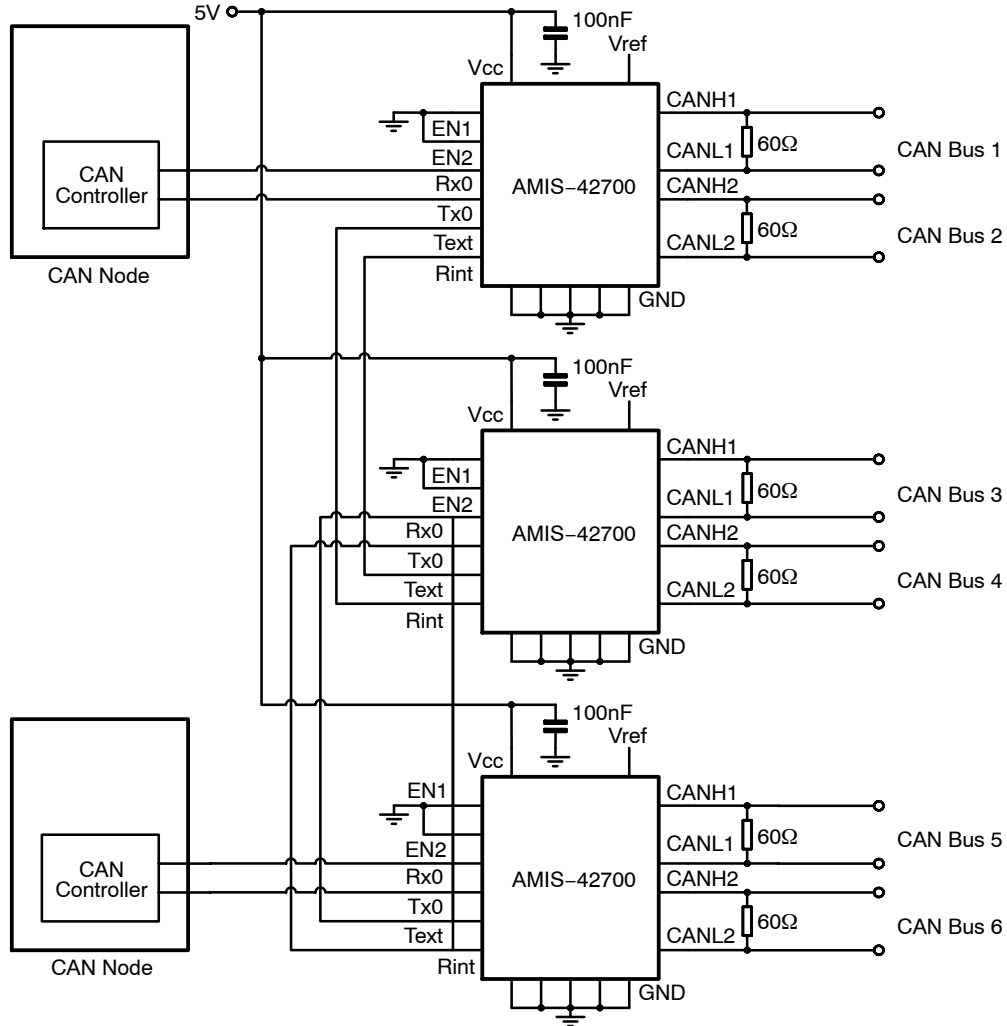



Figure 5. Adding CAN Nodes in Network Connection Board

By connecting the 2 CAN nodes as in above figure, two CAN transceivers can be saved making the application cheaper.

Conclusion

By using AMIS-42700, a multiple CAN bus network can be built in a very easy and cheap way. Additionally, the multiple CAN bus network will make the complete network more fault tolerant (safety) as also could save several meters of wire.

If the same CAN baudrate can be obtained as in the original application depends on the bus topology.

ON Semiconductor and  are registered trademarks of Semiconductor Components Industries, LLC (SCILLC). SCILLC reserves the right to make changes without further notice to any products herein. SCILLC makes no warranty, representation or guarantee regarding the suitability of its products for any particular purpose, nor does SCILLC assume any liability arising out of the application or use of any product or circuit, and specifically disclaims any and all liability, including without limitation special, consequential or incidental damages. "Typical" parameters which may be provided in SCILLC data sheets and/or specifications can and do vary in different applications and actual performance may vary over time. All operating parameters, including "Typicals" must be validated for each customer application by customer's technical experts. SCILLC does not convey any license under its patent rights nor the rights of others. SCILLC products are not designed, intended, or authorized for use as components in systems intended for surgical implant into the body, or other applications intended to support or sustain life, or for any other application in which the failure of the SCILLC product could create a situation where personal injury or death may occur. Should Buyer purchase or use SCILLC products for any such unintended or unauthorized application, Buyer shall indemnify and hold SCILLC and its officers, employees, subsidiaries, affiliates, and distributors harmless against all claims, costs, damages, and expenses, and reasonable attorney fees arising out of, directly or indirectly, any claim of personal injury or death associated with such unintended or unauthorized use, even if such claim alleges that SCILLC was negligent regarding the design or manufacture of the part. SCILLC is an Equal Opportunity/Affirmative Action Employer. This literature is subject to all applicable copyright laws and is not for resale in any manner.

PUBLICATION ORDERING INFORMATION

LITERATURE FULFILLMENT:

Literature Distribution Center for ON Semiconductor
P.O. Box 5163, Denver, Colorado 80217 USA
Phone: 303-675-2175 or 800-344-3860 Toll Free USA/Canada
Fax: 303-675-2176 or 800-344-3867 Toll Free USA/Canada
Email: orderlit@onsemi.com

N. American Technical Support: 800-282-9855 Toll Free
USA/Canada
Europe, Middle East and Africa Technical Support:
Phone: 421 33 790 2910
Japan Customer Focus Center
Phone: 81-3-5773-3850

ON Semiconductor Website: www.onsemi.com
Order Literature: <http://www.onsemi.com/orderlit>
For additional information, please contact your local
Sales Representative